

HEKO_N



**Multilayer
Ceramic
Capacitors**



TABLE OF CONTENTS

DESIGN	SERIES	RATED VOLTAGE	CERAMICS	CAPACITANCE RANGE	PAGE	
General Information					3	
Technical Data					4	
Chip Capacitors	VP1	50,100V	CG (NPO) 2R1 (X7R) 2F4 (Y5V)	1pF to 100nF 100pF to 2.7µF 1nF to 10µF	8	
					9	
					10	
	VP1	250, 300, 500V	CG (NPO) 2R1 (X7R) 2F4 (Y5V)	1pF to 33nF 100pF to 1µF 1nF to 1.2µF	11	
					12	
					13	
	Chip Size					5
Ordering Code					5	
Recommendation for Surface Mounting					6	
Packaging					7	
High Voltage Chip Capacitors	HV1	1 - 5KV	CG (NPO) 2R1 (X7R)	1pF to 8.2nF 100pF to 82nF	14 15	
	HV1	1 – 10kV	CG (NPO) 2R1 (X7R)	1pF to 120nF 100pF to 1.8µF	16, 17	
Ceramic Chip Safety Capacitors Class X, Y 	HM1	250Vac	2R1 (X7R)	0,1nF to 22nF	18	
					Features	18
					Technical data	18
					Voltage tests	19
					Rated capacitance lists	20
					Ordering code	21
					Marking	21
Packaging	21					
Radial MLC Capacitors	VP2, HV2	50 - 500V 1 - 10kV	CG (NPO) 2R1 (X7R) 2F4 (Y5V)	1pF to 150nF 100pF to 1µF 1nF to 10µF	22	
					Packaging	23
Ordering Code					23	
Test methodes					24	
Production tests					26	
Basic Capacitor Formulas					26	

GENERAL INFORMATION

GENERAL: The ceramic multilayer chip capacitors consist of formulated ceramic dielectric materials in layers interspersed with metal electrode layers. The entire structure is fired together at high temperature, after which conductive terminations are applied on opposite ends to contact protruding electrode edges. Termination materials vary depending on the intended use.

Kekon produces multilayer ceramic capacitors (MLC) in two versions, leaded devices and surface mounted chips (SMD).

For leaded styles tinned leads are soldered on the termination electrodes and finally the capacitor bodies are coated with the epoxy coating.

Surface mounted chips are available in three kind of terminations: Silver-Palladium (AgPd) electrodes, Nickel-Barrier electrodes, tinned copper.

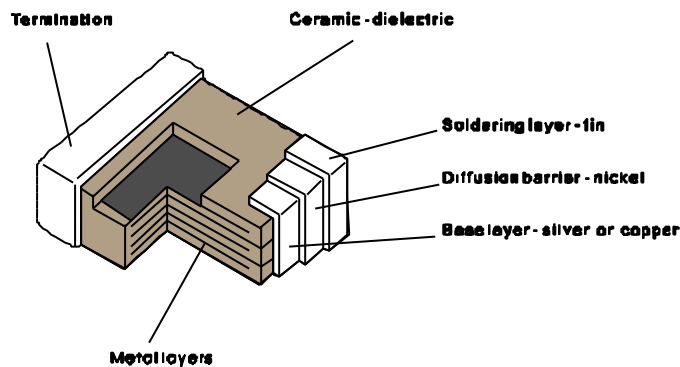

DIELECTRIC TYPE: Kekon ceramic multilayer capacitors are offered in three most popular temperature characteristics. They are designed according to international specification IEC (or to EIA) as the ultrastable CG, known as NP0 (C0G), the stable 2R1 (X7R) and the general purpose 2F4 (Y5V). NP0 dielectric is made of ceramic materials which are not ferroelectric. This yields a superior stability characteristic, but relatively low capacitance.

Both 2R1 (X7R) and 2F4 (Y5V) are made from ferroelectric materials, principally barium titanate.

The NP0 capacitors are used in applications which require very stable characteristics with no dependence of capacitance and dissipation factor ($\tan\delta$) on time, voltage and frequency. The dissipation factor ($\tan\delta$) is relatively low.

Capacitors of the ferroelectric types have a non-linear temperature characteristics, the capacitance and $\tan\delta$ are effected by temperature, voltage and frequency. The dissipation factor is usually higher than NP0.

AGING: Ferroelectric materials also exhibit a time dependence, known as aging. It is believed that this behavior is due to strain energy of the ferroelectric domains striving for orientation relative to one another after their formation. Thus, ferroelectric materials exhibit an aging of the dielectric constant after cooling below the Curie temperature, which is logarithmic with time.

The aging rate of capacitors is expressed in terms of decade hours. 2R1 (X7R) dielectrics, for example, ages at 2% per decade hour; i.e. the capacitors will lose 2% capacity between 1 and 10 hours after cooling, and additional 2% between 10 and 100 hours and an additional 2% between 100 and 1000 hours.

The aging process of ferroelectrics is reversible. Heating the material past the Curie point reverts the domains structure to its previous state and the aging process starts anew. Users should be aware that certain capacitor attachment processes do exceed the Curie temperature of the dielectric and, therefore, a temporary increase in capacitance should be expected. The rated C-tolerance of capacitors is defined for 1000 hours of aging.

VOLTAGE EFFECTS: Ferroelectric materials are also affected by applied voltage, both AC and DC. As the voltage is increased towards the rated voltage, the capacitance will decrease. This decrease in capacitance is a function of dielectric thickness and dielectrics itself.

This decrease in capacitance is due to a polarizing effect in the ferroelectric material.

In a specific voltage range (close to the breakdown voltage) a varistor effect can be measured.

FREQUENCY EFFECTS: Frequency affects capacitance, dissipation factor and impedance of capacitors. Increased frequency results in a decrease of the measured capacitance value and in a increase of dissipation factor. The effect is common to the all dielectric types, but is more pronounced in high dielectric constant formulations.

MECHANICAL STRESS EFFECTS: Dielectric material exhibit some low level electrostriction and piezoelectric behavior.

Electrostriction means that an electric field causes deformation, but an mechanical stress does not produce an electric field.

Piezoelectricity means that a mechanical stress does produce an electric field and an electric field causes deformation. It is a two-sided relationship.

DIELECTRIC ABSORPTION: It is a residual voltage measured on a capacitors after discharge. High dielectric constant formulations display more dielectric absorption.

CORONA: The ionization of air causes lower insulation properties on surface of capacitors and can in time cause failures.

CUSTOMER TESTING: Because of the temperature and voltage effects, caution must be used in establishing a testing sequence. Dielectric strength and insulation resistance tests both apply DC voltage and depress capacitance, so capacitance should be measured prior to the voltage tests.

For temperature tests, it is recommendable that 2R1 and 2F4 capacitors be de-aged for 2 hours at 125°C and stabilized at room temperature for 24 hours before capacitance measurements are done.

For more information on capacitors, dielectrics and performances contact the factory directly.

TECHNICAL DATA

PARAMETER	DIELECTRIC		
	CG (NP0)	2R1 (X7R)	2F4 (Y5V)
Measuring Frequency (for C, tanδ)	1 MHz for C≤1000pF 1 kHz for C>1000pF	1 MHz for C≤100pF 1 kHz for C>100pF	1 kHz
Capacitance Tolerance *	C, D, G, J, K, M,	K, M, S, Z	M, S, Z
Dissipation Factor tanδ	15 · 10 ⁻⁴ for C≥50pF or 1.5(150/C+7)10 ⁻⁴	350 · 10 ⁻⁴	350 · 10 ⁻⁴
Measuring Voltage (C, tanδ)	1 Vrms	0,3 Vrms	0,3 Vrms
Rated Voltage	16V – 10kV		
Test Voltage (16V – 10kV) **	16 - 100V 2,5xUr 200 – 500V 1,5xUr + 100V > 500V 1,2xUr		
Insulating Resistance Ri	≥10GΩ or RixC≥100ΩF whichever is less	≥4GΩ or RixC≥100ΩF whichever is less	≥4GΩ or RixC≥100ΩF whichever is less
Measuring Voltage (for Ri)	16-500V Ur >500V 500V		
Temperature Range	-55°C to +125°C	-55°C to +125°C	-25°C to +85°C
Temperature Characteristics	0 ± 30 ppm/°C	± 15%	+30% / -80%
Climatic Category	55 / 125 / 56	55 / 125 / 56	25 / 85 / 21
Reference Temperature	23°C		
Voltage Dependence	No	Yes	Yes
Aging (per hour decade)	0	<2%	<6%
Termination (chip)	AgPd or Ni barrier or Cu/Sn		
Packaging	Bulk or Taped		
Standard	IEC 384 – 10 IEC 384 –8,9 for leaded IEC 60286-3 for taped SMD		

* Capacitance tolerance, see Ordering Code

** Units rated above 1000V may require conformal coating in use to preclude arcing over the chip surface

Capacitance as a function of temperature

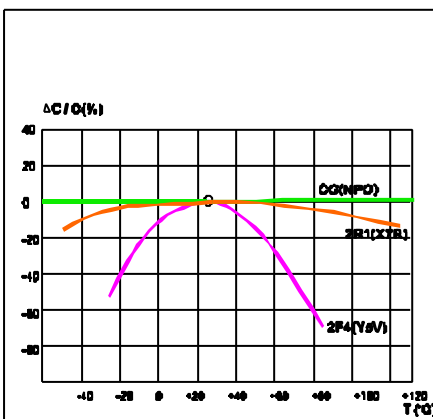

Capacitance as a function of DC voltage (Ur=50V)

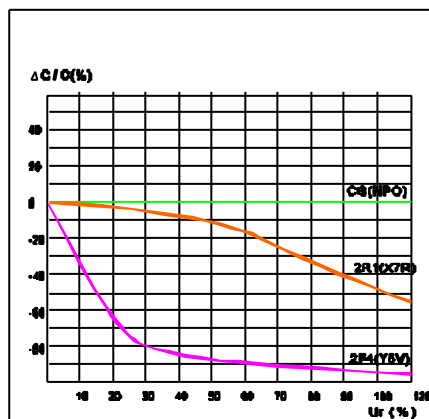

Capacitance as a function of frequency

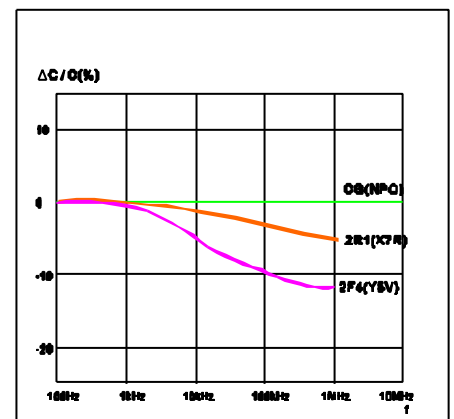

CHIP SIZE 16 – 10000 Vdc

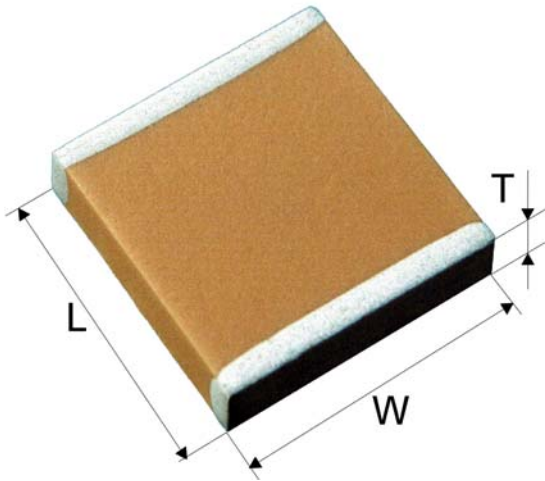

Size	L	W	T _{max}
0402	1.25 ±0.15	0.5 ±0.15	0.6
0504	1.25 ±0.15	1.0 ±0.1	0.95
0603	1.6 ±0.15	0.8 ±0.15	0.95
0805	2.0 ±0.2	1.25 ±0.2	1.2 *
1206	3.2 ±0.3	1.6 ±0.2	1.5 *
1210	3.2 ±0.4	2.5 ±0.3	2,5
1808	4.5 ±0.4	2.0 ±0.3	2,0
1812	4.5 ±0.5	3.2 ±0.4	3.0
1825	4.5 ±0.5	6.3 ±0.5	3.0
2220	5.7 ±0.5	5.0 ±0.5	3.0
2225	5.7 ±0.5	6.3 ±0.5	3.0
1515	3.8 ±0.4	3.8 ±0.4	3.0
2020	5.0 ±0.5	5.0 ±0.5	4.0
2520	6.3 ±0.5	5.0 ±0.5	4.0
3530	8.89 ±0.9	7.62 ±0.8	5.0
4020	10.2 ±1.0	5.0 ±0.5	5.0
4040	10.2 ±1.0	10.2 ±1.0	5.0
4540	11.4 ±1.0	10.2 ±1.0	5.0
5040	12.7 ±2.0	10.2 ±1.0	6.5
5440	13.7 ±1.4	10.2 ±1.0	6.5
5550	14.0 ±1.4	12.7 ±1.3	6.5
6560	16.5 ±1.6	15.2 ±1.5	6.5
6660	16.7 ±1.6	15.2 ±1.5	6.5
7565	19.50 ±1.9	16.5 ±1.6	6.5

* Tmax 0,63mm available on request

Ordering Code

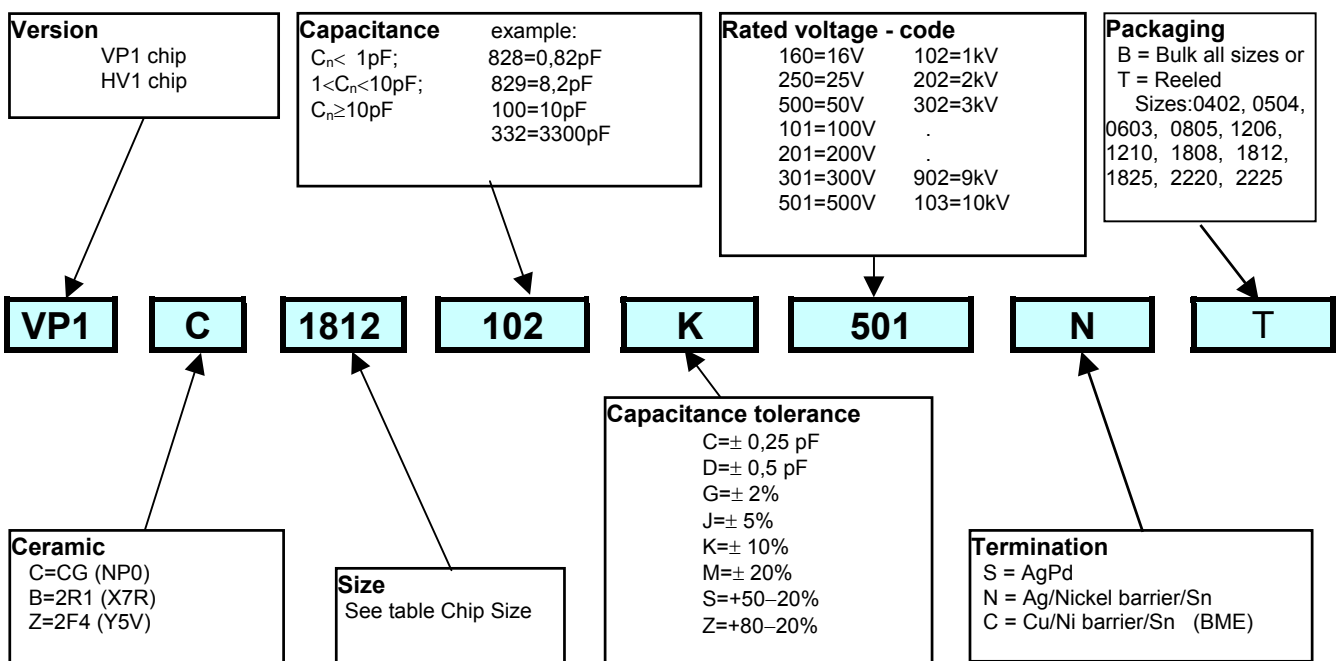

RECOMMENDATION FOR SURFACE MOUNTING

1. Soldering Methods:

Soldering methods commonly used in the industry and recommended are Infrared Reflow Soldering, Wave Soldering and Vapor Phase Soldering. If hand soldering cannot be avoided care should be taken not only in soldering, but also in correct component handling.

2. Solder Heat and Thermal Shock:

Ceramic material is very sensitive to quick changes in temperature, therefore it is very important to avoid sudden temperature cycles during the soldering process. Sudden heating may cause microcracks in the ceramics and consequently may reduce the insulation resistance and withstand voltage. The risk increases with the size of the chips.

All soldering methods involve thermal cycling of the capacitors. The rate of heating and cooling must be controlled to avoid thermal shocks cracking of the MLC chips. In general the components should be preheated with a heating speed of around 2°C per second and even slower for large chips, up to a temperature of maximum 100°C under soldering temperature (ΔT). A soak at the end of the pre-heat is useful when larger components are soldered.

A recommended Temperature - Time profile for most soldering systems is shown in Fig. 1

3. Solder Time:

Solder melting time should be minimized. The maximum permissible solder time that a MLC chip may be subjected to is depended upon the termination material and soldering process and temperature of solder.

Figure 2 shows comparative Temperature / Time data for silver palladium and nickel barrier or tinned copper terminations.

Typical solder times are:

Wave Soldering	3 - 5 sec. at 250°C
Infrared Reflow	7 - 10 sec. at 225°C
Vapor Phase	15 - 20 sec. at 215°C

Cooling to ambient should be allowed to occur naturally.

4. Handling:

Chip ceramic capacitors should be handled with care to avoid any mechanical damage and chip surface contamination.

5. Solderability:

Applying a mildly activated fluxes are preferred. Terminations should be well soldered after immersion in a solder bath (60Sn/40Pb) at 235±5°C for 2±1sec.

6. Solder Deposition

If too much solder is deposited, the chip will become more susceptible to the thermal and mechanical stress that result from solder contraction, and it could break. If not enough solder is deposited, adhesion to the terminal electrodes will be weak, which could the chip to work loose. A solder film thickness of 200 – 250 μm is recommended.

7. Cleaning:

MLC chip capacitors can withstand the commonly used cleaning agents, such as water, alcohol and degreaser solvents. Be careful that no flux residues are left on the chip surface.

8. Shelf Life:

Capacitors will be solderable for a minimum of one year from the date of shipment, if they are stored properly (dry environment) in the original packaging.

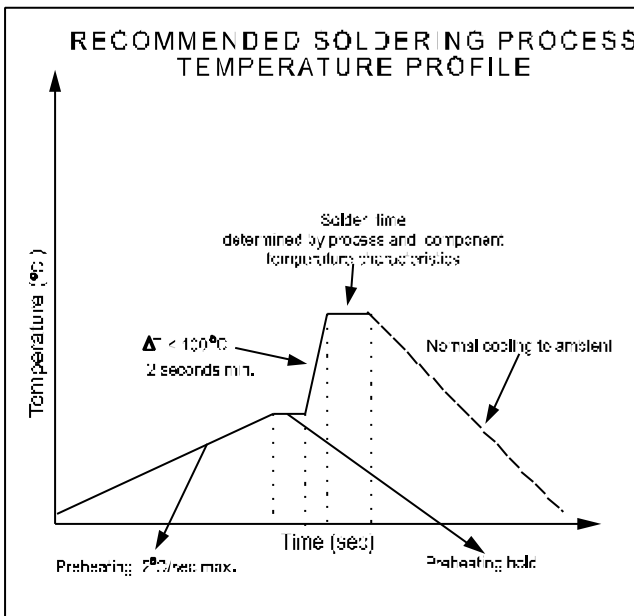

Fig. 1: Recommended Soldering Process Profile

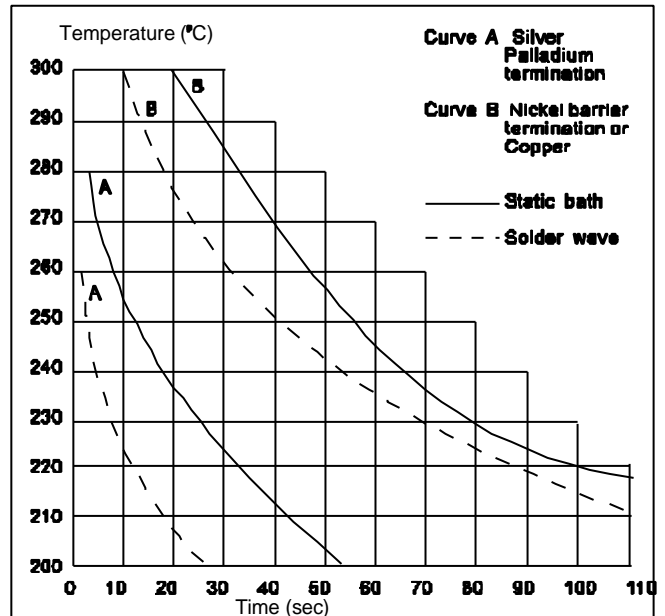
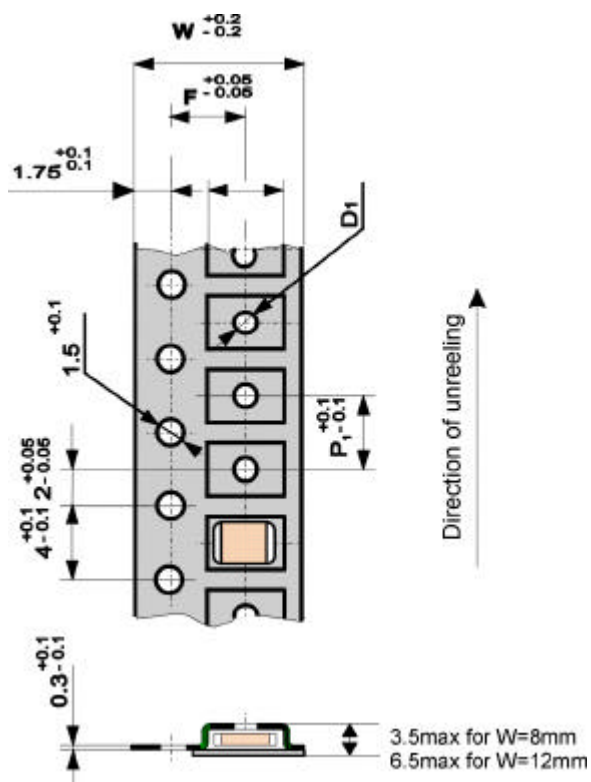

Fig. 2: Solder Time Temperature Curves

PACKAGING



Tape dimensions

(Unit: mm)

Size	0504	0603	0805	1206	1210	1808	1812	1825	2220	2225
P ₁	4	4	4	4	4	8	8	8	8	8
F	3.5	3.5	3.5	3.5	3.5	5.5	5.5	5.5	5.5	5.5
W	8	8	8	8	8	12	12	12	12	12
T	8.4	8.4	8.4	8.4	8.4	12.4	12.4	12.4	12.4	12.4
D ₁ min	1	1	1	1	1	1.5	1.5	1.5	1.5	1.5

Packing unit

(Unit max: pcs)

Size	0504	0603	0805	1206	1210	1808	1812	1825	2220	2225	1515
Reel 180mm	4.000	4.000	4.000	4.000	4.000	1.500	1.500	1.000	1.000	1.000	/
Reel 330mm	16.000	16.000	16.000	16.000	16.000	6.000	6.000	4.000	4.000	4.000	/
Bulk 200x100x50mm	12.000	12.000	12.000	12.000	12.000	3.000	3.000	3.000	3.000	3.000	3000

Size	2020	2520	3530	4020	4040	4540	5040	5440	5555, 6560, 6560, 7565
Bulk 200x100x50mm	3.000	3.000	2.000	2.000	1.000	1.000	1.000	1.000	500

Quantity per reel varies with the chip thickness.



CG (NP0) 50 and 100V

Size										
	0504	0603	0805	1206	1210	1808	1812	2220	2225	
L (mm)	1.25	1.6	2.0	3.2	3.2	4.5	4.5	5.7	5.7	
W (mm)	1.0	0.8	1.25	1.6	2.5	2.0	3.2	5.0	6.3	
M (mm)	0.3 ±0.15	0.3 ±0.15	0.5 ±0.2	0.6 ±0.3	0.6 ±0.3	0.6 ±0.3	0.6 ±0.3	0.6 ±0.3	0.6 ±0.3	
Tmax (mm)	0.95	0.95	1.2	1.5	2.5	2.0	3.0	3.0	3.0	
Rated voltage										
Cn Code	50V 100V	50V 100V	50V 100V	50V 100V	50V 100V	50V 100V	50V 100V	50V 100V	50V 100V	50V 100V
1 - 8.2pF					100	100	100			
10 100										
12 120										
15 150										
18 180										
22 220								270	270	
27 270										
33 330										
39 390										
47 470										
56 560										
68 680										
82 820										
100 101										
120 121										
150 151										
180 181										
220 221										
270 271										
330 331										
390 391										
470 471										
560 561										
680 681										
820 821	681	681								
1nF 102										
1.2 122										
1.5 152										
1.8 182										
2.2 222				182						
2.7 272										
3.3 332										
3.9 392			332							
4.7 472										
5.6 562										
6.8 682					562					
8.2 822										
10 103										
12 123				103		103				
15 153							123			
18 183								183		
22 223										
27 273					223	223				
33 333										
39 393							333			
47 473										
56 563										
68 683										
82 823								563		
100 104									683	
120 124								823		
150 154									104	
180 184										
220 224										
270 274										
330 334										
390 394										

2R1 (X7R) 50 and 100V

Size									
	0504	0603	0805	1206	1210	1808	1812	2220	2225
L (mm)	1.25	1.6	2.0	3.2	3.2	4.5	4.5	5.7	5.7
W (mm)	1.0	0.8	1.25	1.6	2.5	2.0	3,2	5.0	6,3
M (mm)	0.3 ^{±0.05}	0.3 ^{±0.05}	0.5 ^{±0.2}	0.6 ^{±0.3}	0.6 ^{±0.3}	0.6 ^{±0.3}	0.6 ^{±0.3}	0.6 ^{±0.3}	0.6 ^{±0.3}
Tmax (mm)	0.95	0.95	1.2	1.5	2.5	2.0	3.0	3.0	3.0
Rated voltage									
Cn	Code	50V 100V	50V 100V	50V 100V	50V 100V	50V 100V	50V 100V	50V 100V	50V 100V
100pF	101								
	120								
	150								
	180								
	220								
	270								
	271				331				
	330								
	331								
	390					471	471		
	470								
	471								
	560								
	561								
	680								
	681								
	820							102	
	821								
1nF	102								
	1.2								
	1.5								
	1.8								
	2.2							222	222
	2.7								
	272								
	3.3								
	332								
	3.9								
	392								
	4.7								
	472								
	5.6								
	562								
	6.8								
	682								
	8.2								
	822								
	10								
	103								
	12								
	123								
	15								
	153								
	18								
	183								
	22								
	223								
	27		223						
	273								
	33	273							
	333		273						
	39								
	393								
	47								
	473								
	56								
	563								
	68								
	683								
	82								
	823								
	100								
	104								
	120								
	124								
	150								
	154								
	180								
	184								
	220								
	224								
	270								
	274								
	330								
	334								
	390								
	394								
	470								
	474								
	560								
	564								
	680								
	684								
	820								
	824								
1.0 F	105								
	1.2								
	125								
	1.5								
	155								
	1.8								
	185								
	2.2								
	225								
	2.7								
	275								
	3.3								
	335								
	3.9								
	395								
	4.7								
	475								
	5.6								
	565								
	6.8								
	685								
	8.2								
	825								



2F4 (Y5V) 50 and 100V

Size												
	0504	0603	0805	1206	1210	1808	1812	2220	2225			
L (mm)	1.25	1.6	2.0	3.2	3.2	4.5	4.5	5.7	5.7			
W (mm)	1.0	0.8	1.25	1.6	2.5	2.0	3,2	5.0	6,3			
M (mm)	0.3 ^{±0.05}	0.3 ^{±0.05}	0.5 ^{±0.2}	0.6 ^{±0.3}	0.6 ^{±0.3}	0.6 ^{±0.3}	0.6 ^{±0.3}	0.6 ^{±0.3}	0.6 ^{±0.3}			
Tmax (mm)	0.95	0.95	1.2	1.5	2.5	2.0	3.0	3.0	3.0			
Rated voltage												
Cn	50V		50V		50V		50V		50V		50V	
Code	100V	100V	100V	100V	100V	100V	100V	100V	100V	100V	100V	
2.2nF												
2.7												
3.3												
3.9					472							
4.7												
5.6												
6.8												
8.2						103	103					
10												
12												
15												
18												
22												
27												
33												
39												
47								473				
56	393	393										
68												
82									104	104		
100												
120												
150												
180												
220				184								
270												
330			274									
390												
470												
560												
680												
820					684							
1.0 F												
1.2				105								
1.5						125	125					
1.8						155	155					
2.2												
2.7									225			
3.3												
3.9									275			
4.7												
5.6												
6.8												
8.2												
10										825	825	
12									106			
15												
18												
22												
27												
33												
39												
47												
56												
68												
82												
100												

CG (NP0) 250, 300, 500V

Size							
	0805	1206	1210	1808	1812	2220	2225
L (mm)	2.0	3.2	3.2	4.5	4.5	5.7	5.7
W (mm)	1.25	1.6	2.5	2.0	3.2	5.0	6.3
M (mm)	0.5 ±0.2	0.6 ±0.3	0.6 ±0.3	0.6 ±0.3	0.6 ±0.3	0.6 ±0.3	0.6 ±0.3
Tmax (mm)	1.2	1.5	2.5	2.0	3.0	3.0	3.0
Rated voltage							
Cn	Code	250V 300V 500V	250V 300V 500V	250V 300V 500V	250V 300V 500V	250V 300V 500V	250V 300V 500V
1 - 8.2pF							
10	100						
12	120						
15	150						
18	180			221	221	221	221
22	220						
27	270						
33	330						
39	390						
47	470						
56	560						
68	680						
82	820						
100	101						
120	121						
150	151						
180	181						
220	221						
270	271						
330	331						
390	391						
470	471						
560	561	471					
680	681						
820	821	681					
1nF	102						
1,2	122						
1,5	152	122					
1,8	182						
2,2	222		182				
2,7	272				222		
3,3	332		272		272		
3,9	392						
4,7	472					392	
5,6	562				472		
6,8	682			562			
8,2	822				682	682	
10	103					822	
12	123						
15	153						
18	183						
22	223						
27	273						
33	333					273	
39	339						103
							183
							223
							153
							333



2R1 (X7R) 250, 300, 500V

Size																					
	0805			1206			1210			1808			1812			2220			2225		
L (mm)	2.0			3.2			3.2			4.5			4.5			5.7			5.7		
W (mm)	1.25			1.6			2.5			2.0			3.2			5.0			6.3		
M (mm)	0.5 ±0.2			0.6 ±0.3			0.6 ±0.3			0.6 ±0.3			0.6 ±0.3			0.6 ±0.3			0.6 ±0.3		
Tmax (mm)	1.2			1.5			2.5			2.0			3.0			3.0			3.0		
Rated voltage																					
Cn	250V	300V	500V	250V	300V	500V	250V	300V	500V	250V	300V	500V	250V	300V	500V	250V	300V	500V	250V	300V	500V
Code																					
100pF																					
120																					
150																					
180																					
220																					
270																					
330																					
390																					
470																					
560																					
680																					
820																			102		102
1nF																					
1,2																					
1,5																					
1,8																					
2,2																					
2,7																					
3,3																					
3,9																					
4,7																					
5,6																					
6,8																					
8,2																					
10																					
12																					
15																					
18																					
22																					
27																					
33																					
39																					
47																					
56																					
68																					
82																					
100																					
120																					
150																					
180																					
220																					
270																					
330																					
390																					
470																					
560																					
680																					
820																					
1.0 F																					
1.2																					

2F4 (Y5V) 250, 300, 500V

Size							
	0805	1206	1210	1808	1812	2220	2225
L (mm)	2.0	3.2	3.2	4.5	4.5	5.7	5.7
W (mm)	1.25	1.6	2.5	2.0	3.2	5.0	6.3
M (mm)	0.5 ±0.2	0.6 ±0.3	0.6 ±0.3	0.6 ±0.3	0.6 ±0.3	0.6 ±0.3	0.6 ±0.3
Tmax (mm)	1.2	1.5	2.5	2.0	3.0	3.0	3.0
Rated voltage							
Cn Code	250V 300V 500V	250V 300V 500V	250V 300V 500V	250V 300V 500V	250V 300V 500V	250V 300V 500V	250V 300V 500V
1.2nF 122							
1.5 152							
1.8 182							
2.2 222							
2.7 272			332	332			
3.3 332							
3.9 392							
4.7 472							
5.6 562							
6.8 682							
8.2 822						103	
10 103							
12 123							153
15 153							153
18 183		153					
22 223							
27 273							
33 333	273						
39 393							
47 473							
56 563			473	473	473		
68 683	563	563					
82 823							
100 104							
120 124		124	104	104	104		
150 154							
180 184						154	154
220 224							
270 274							
330 334			274	274	274		
390 394							
470 474							
560 564							
680 684					564		
820 824						684	684
1.0uF 105							
1,2 125						125	125
1,5 155							
1,8 185							
2,2 225							
2,7 275							
3,3 335							
3,9 395							
4,7 475							
5,6 565							
6,8 685							
8,2 825							
10 106							
12 126							



CG (NP0) 1 - 5 kV

Size							
	0805	1206	1210	1808	1812	1825	2220
L (mm)	2.0	3.2	3.2	4.5	4.5	4.5	5.7
W (mm)	1.25	1.6	2.5	2.0	3.2	6.3	5.0
M (mm)	1 ^{+0.5/-1}	1 ^{+0.5/-1}	1 ^{+0.5/-1}	1 ^{+0.5/-1}	1 ^{+0.5/-1}	1 ^{+0.5/-1}	1 ^{+0.5/-1}
Tmax (mm)	1.3	1.5	2.5	2.0	3.0	4.0	4.0
Rated voltage							
Cn Code	1kV	1kV 2kV	1kV 2kV	1kV 2kV 3kV 4kV	1kV 2kV 3kV 4kV	1kV 2kV 3kV 4kV 5kV	1kV 2kV 3kV 4kV 5kV
1 - 8.2pF			100	100			
10 100							
12 120							
15 150							
18 180							
22 220							
27 270					330		
33 330						390	390
39 390							
47 470							
56 560							
68 680							
82 820							
100 101							
120 121							
150 151							
180 181							
270 221					181		
270 271							
330 331		271		331		331	
390 391	331						
470 471							
560 561							471
680 681						561	
820 821			681				
1nF 102		821		821			
1,2 122						122	
1,5 152							122
1,8 182							
2,2 222			182				182
2,7 272				222	222		
3,3 332							
3,9 392							
4,7 472						392	
5,6 562							392
6,8 682							
8,2 822						822	822
10 103							
12 123							
15 153							
18 183							
22 223							

2R1 (X7R) 1 - 5kV

Size							
	0805	1206	1210	1808	1812	1825	2220
L (mm)	2.0	3.2	3.2	4.5	4.5	4.5	5.7
W (mm)	1.25	1.6	2.5	2.0	3.2	6.3	5.0
M (mm)	$1^{+0.5/-1}$	$1^{+0.5/-1}$	$1^{+0.5/-1}$	$1^{+0.5/-1}$	$1^{+0.5/-1}$	$1^{+0.5/-1}$	$1^{+0.5/-1}$
Tmax (mm)	1.2	1.5	2.5	2.0	3.0	4.0	4.0
Rated voltage							
Cn Code	1kV	1kV 2kV	1kV 2kV	1kV 2kV 3kV	1kV 2kV 3kV 4kV	1kV 2kV 3kV 4kV	1kV 2kV 3kV 4kV 5kV
100pF 101							
120 121							
150 151							
180 181							
220 221							
270 271							
330 331							
390 391					471	471	471
470 471							
560 561							
680 681						561	
820 821							
1nF 102		821			821		
1.2 122							102
1.5 152							
1.8 182							
2.2 222						182	182
2.7 272	222						
3.3 332			272		272		
3.9 392							
4.7 472							
5.6 562							
6.8 682		682					
8.2 822					682	682	682
10 103							
12 123			123				
15 153							
18 183				183			
22 223							
27 273							
33 333					333		
39 393						273	273
47 473							
56 563							
68 683						683	
82 823							
100 104							823
120 124							
150 154							
180 184							
220 224							
270 274							
330 334							
390 394							
470 474							
560 564							
680 684							



HIGH VOLTAGE CHIP CAPACITORS 1-10kV

APPLICATION





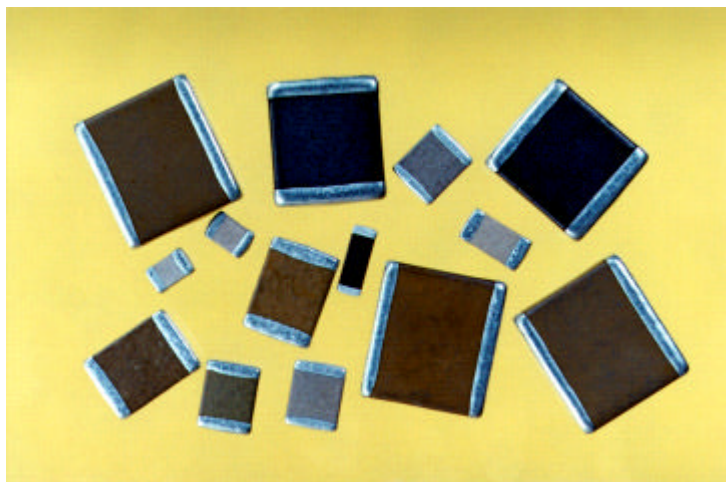

- DC-DC converters
- Voltage multipliers
- Radio and TV receiver
- Modems, Interfaces
- Other electrical appliances where high voltage is present

FEATURES

- Ceramic capacitor specially designed for high voltage applications
- Capacitance range: up to 1 μ F
- Rated voltage: up to 10kVdc
- Sizes: from 1515 up to 7565
- CG(NPO) and 2R1 (X7R) temperature characteristics
- Operating temperature range - 55°C to +125°C
- Compliant to Standard IEC 384-10



NOTE: High voltage chips require more precautions be taken in applying these chips at surface mounting.

Chip														
Size	1515	2020	2225	2520	3530	4020	4040							
L (mm)	3.81 \pm 0.38	5.08 \pm 0.51	5.7 \pm 0.6	6.35 \pm 0.64	8.89 \pm 0.89	10.2 \pm 1.0	10.2 \pm 1.0							
W (mm)	3.81 \pm 0.38	5.08 \pm 0.51	6.3 \pm 0.6	5.08 \pm 0.51	7.62 \pm 0.76	5.08 \pm 0.51	10.2 \pm 1.0							
T (mm)	3.5	3.9	4.0	4.5	5.1	5.1	5.1							
Maximum capacitance code														
Rated Voltage	CG	2R1	CG	2R1	CG	2R1	CG	2R1	CG	2R1	CG	2R1	CG	2R1
1 kV	392	333	682	683	123	124	103	104	183	274	123	184	333	474
2 kV	222	392	472	103	103	183	682	153	123	683	822	333	223	104
3 kV	561	122	122	332	102	562	222	822	682	333	392	223	123	393
4 kV			821	182	681	272	152	392	472	183	272	123	822	273
5 kV			391	102	561	152	561	222	222	822	152	562	332	183
6 kV							680		122	472	821	322	182	123
7 kV									821	332	471	222	152	822
8 kV													152	562
9 kV														
10 kV														

Technical Data

PARAMETER	CG(NPO) dielectric	2R1(X7R) dielectric
Capacitance Tolerance *	J,K,M,S	K,M,S,Z
Dissipation Factor $\tan\delta$	15 10^{-4}	350 10^{-4}
Measuring Voltage (C, $\tan\delta$)	1 Vrms	0,3 Vrms
Rated Voltage	1kV – 10kV	
Test Voltage **	1,2xUr	
Insulating Resistance Ri	$\geq 10G\Omega$ or $RiXC \geq 100\Omega F$ whichever is less	$\geq 4G\Omega$ or $RiXC \geq 100\Omega F$ whichever is less
Measuring Voltage (for Ri)	500V	500V
Temperature Range	-55°C to +125°C	-55°C to +125°C
Temperature Characteristics	0 \pm 30 ppm/°C	\pm 15%
Climatic Category	55 / 125 / 56	55 / 125 / 56
Reference Temperature	23°C	
Voltage Dependence	No	Yes
Aging (per hour decade)	0	<2%
Termination	AgPd or Ni barrier or Cu/Sn	
Packaging	Bulk	
Standard	IEC 384-10	

* Capacitance tolerance, see Ordering Code

** Units rated above 1000V may require conformal coating in use to preclude arcing over the chip surface

Chip														
Size	4540	5040	5440	5550	6560	6660	7565							
L (mm)	11.4 \pm 1.1	12.7 \pm 1.3	13.7 \pm 1.4	14.0 \pm 1.4	16.5 \pm 1.7	16.8 \pm 1.7	19.0 \pm 1.9							
W (mm)	10.2 \pm 1.0	10.2 \pm 1.0	10.2 \pm 1.0	12.7 \pm 1.3	15.2 \pm 1.5	15.2 \pm 1.5	16.5 \pm 1.7							
T (mm)	5.1	5.1	6.4	6.4	6.4	6.4	6.4							
<div style="border: 1px solid black; padding: 5px; display: inline-block;">Maximum capacitance code</div>														
Rated Voltage	CG	2R1	CG	2R1	CG	2R1	CG	2R1	CG	2R1	CG	2R1	CG	2R1
1 kV	393	564	393	474	473	684	563	824	104	125	104	125	124	185
2 kV	273	124	273	823	333	124	393	184	683	334	683	334	823	474
3 kV	153	563	153	563	183	823	223	104	393	184	393	184	473	224
4 kV	103	333	103	273	123	393	153	563	223	104	223	104	393	154
5 kV	392	223	392	153	472	223	562	393	123	473	123	473	153	823
6 kV	222	123	272	123	332	153	392	223	682	333	682	333	103	563
7 kV	182	822	182	822	222	103	272	153	562	223	562	223	822	393
8 kV	152	682	152	562	182	822	272	123	392	153	392	153	562	333
9 kV	152	562	122	472	182	682	222	103	332	123	332	123	472	273
10 kV	122	392	102	332	152	472	222	822	272	103	272	103	392	223

CERAMIC CHIP SAFETY CAPACITORS CLASS X and Y



APPLICATION





- Switching power supply
- Radio and TV receiver
- Telephone, facsimile, modem
- Other electrical appliances where over voltage surge can occur

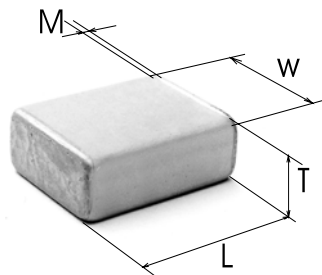

FEATURES

- Ceramic capacitor designed for radio interference suppression for AC Line
- Capacitance range: 470pF to 22nF
- Rated voltage 250 Vac
- Sizes 2220, 4032 and 5040
- Sn plated termination electrodes allow easy soldering
- X7R ($\pm 15\%$) temperature characteristics
- Operating temperature range - 55°C to +125°C
- UL 1414 approved dimensions 2220, 4032 and 5040
- UL file : E210954
- Compliant to Standard IEC 314-14 2nd Ed: Sub - Classes X1, X2, X3, Y1, Y2, Y3



Chip Size					
	1808	1812	2220	4032	5040
L (mm)	4.5 ± 0.4	4.5 ± 0.4	5.7 ± 0.5	10.0 ± 0.6	12.7 ± 1.3
W (mm)	2.0 ± 0.3	3.2 ± 0.4	5.0 ± 0.5	8.0 ± 0.5	10.2 ± 1.0
Tmax(mm)	2.0	3.0	4.0	4.0	6.0
M (mm)	0.2 ± 0.15	0.2 ± 0.15	0.2 ± 0.15	0.2 ± 0.3	0.2 ± 0.3

Technical data

PARAMETER	Value	PARAMETER	Value
Capacitance	See Lists	Temperature Range	-55°C to +125°C
Measuring Frequency (C, tgδ)	1 kHz	Temp. Characteristics	± 15%
Capacitance Tolerance	10%, 20%	Climatic Category	55 / 125 / 56
Dissipation Factor (tgδ)	250 10 ⁻⁴	Reference Temperature	23°C
Measuring Voltage (C, tgδ)	0,3 Vrms	Aging	<2.5% /decade hour
Rated Voltage	250 Vac	Flammability	UL 94V-0
Voltage Tests	See Tables	Termination	Ni-Sn or AgPd
Insulating Resistance (IR)	6 10 ⁹ Ω	Packaging	Bulk, Reeled
Measuring Voltage (for IR)	500 Vdc	Standards	IEC384-14 2 nd Ed UL1414

Voltage Tests for X and Y Classes Capacitors

Class / Test	Voltage Proof		Charge - Discharge	Impulse Voltage	Life test (Endurance)
Conditions	Production 2 s	Sample 1 min.	10000 Cycles 1 per s	24 Impulses 1 per 10 s	1000 hours T=125°C
X1	1075 Vdc	1075 Vdc	354 Vac	4.0 kV	at 312 Vac Once every hour to 1000Vac for 0.1 s
X2				2.5 kV	
X3				None	
Y1	4000 Vac	4000 Vac	354 Vac	8.0 kV	at 425 Vac Once every hour to 1000Vac for 0.1 s
Y2	1500 Vac	1500 Vac	354 Vac	5.0 kV	
Y3				None	

Voltage Test for Line-by-Pass and Across-the-Line Capacitors

Version / Test	Dielectric Withstand Voltage		Discharge Test	Life Test
Conditions	Production 1 s	Sample 1 min	Circuit in UL 1414	1008 hours T=85°C, RH=50%
Line-by-Pass	1500 Vac	1500 Vac	Figure 18.1 U=10 kVdc 50 discharges, interval 5 sec	U=440 Vac once every hour
Across-the-Line	1500 Vac	1500 Vac	Figure 13.2 U= (5+Cr)kV + 240Vac Cr = C Rated in nF 4 discharges, interval 5 sec	U is doubled for 0.1 s



Rated Capacitance of Class X Capacitors

C rated (nF)	X1		X2		X3	
	Size	T _{max} (mm)	Size	T _{max} (mm)	Size	T _{max} (mm)
0.1	1812	2.0	1812	2.0	1808	2.0
0.15	1812	2.0	1812	2.0	1808	2.0
0.22	1812	2.0	1812	2.0	1808	2.0
0.33	2220	2.0	1812	2.0	1808	2.0
0.47	2220	2.0	1812	2.0	1808	2.0
0.56	2220	2.0	1812	2.0	1808	2.0
0.68	2220	2.0	1812	2.0	1808	2.0
0.82	2220	2.0	1812	2.0	1808	2.0
1.0	2220	2.0	2220	2.0	2220	2.0
1.5	2220	2.0	2220	2.0	2220	2.0
2.2	2220	2.0	2220	2.0	2220	2.0
3.3	2220	3.0	2220	3.0	2220	2.0
4.7	2220	4.0	2220	3.0	2220	3.0
5.6	2220	4.0	2220	3.0	2220	3.0
6.8	2220	4.0	2220	4.0	2220	3.0
8.2	4032	3.0	2220	4.0	2220	4.0
10	4032	3.0	2220	4.0	2220	4.0
15	4032	3.0	4032	4.0	2220	4.0
22	5040	4.0	4032	3.0	4032	4.0
33						
47						

Rated Capacitance of Class Y Capacitors

C rated (nF)	Y1		Y2		Y3	
	Size	T _{max} (mm)	Size	T _{max} (mm)	Size	T _{max} (mm)
0.1	5040	3.0	2220	2.0	1812	2.0
0.15	5040	3.0	2220	2.0	1812	2.0
0.22	5040	3.0	2220	2.0	1812	2.0
0.33	5040	3.0	2220	2.0	1812	2.0
0.47	5040	3.0	2220	2.0	2220	2.0
0.68	5040	3.0	2220	2.0	2220	2.0
1.0	5040	3.0	2220	2.0	2220	2.0
1.5	5040	3.0	2220	2.0	2220	2.0
2.2	5040	4.0	2220	3.0	2220	2.0
3.3	5040	5.0	2220	3.0	2220	2.0
4.7	5040	6.0	2220	4.0	2220	3.0
5.6			4032	3.0	2220	4.0
6.8			4032	3.0	4032	3.0
10			4032	4.0	4032	3.0
15			5040	4.0	4032	4.0
22			5040	4.0	5040	4.0
33						
47						

Rated Capacitance of Line-by-Pass and Across-the-Line Capacitors

C rated (nF)	Line-by Pass		Across-the-Line	
	Size	T _{max} (mm)	Size	T _{max} (mm)
0.47	2220	2.0	5040	3.0
0.68	2220	2.0	5040	3.0
1.0	2220	2.0	5040	3.0
1.5	2220	2.0	5040	3.0
2.2	2220	3.0	5040	4.0
3.3	2220	3.0	5040	5.0
4.7	2220	3.0	5040	6.0
5.6	2220	3.0		
6.8	4032	3.0		
10	4032	3.0		
12	4032	3.0		
15	4032	4.0		
22	5040	5.0		
33				

ORDERING CODE

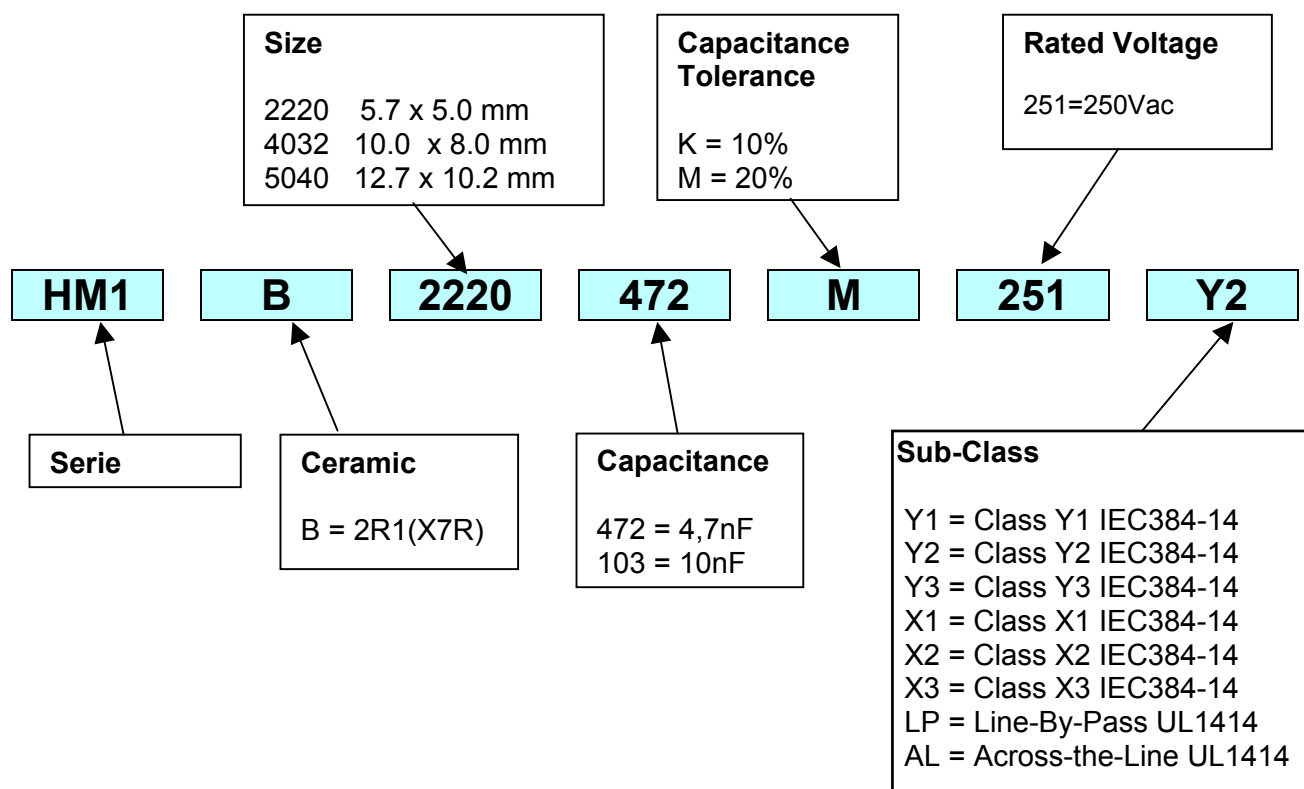

Marking : All dimensions: Marking on the reel

On component for 2220, 4032 and 5040 only:

Trade Mark (K), Version (HM1), C-Code (472), Class (LP)

Marking Example:

K HM1
472LP

Packaging: bulk or reeled

MLC RADIALS

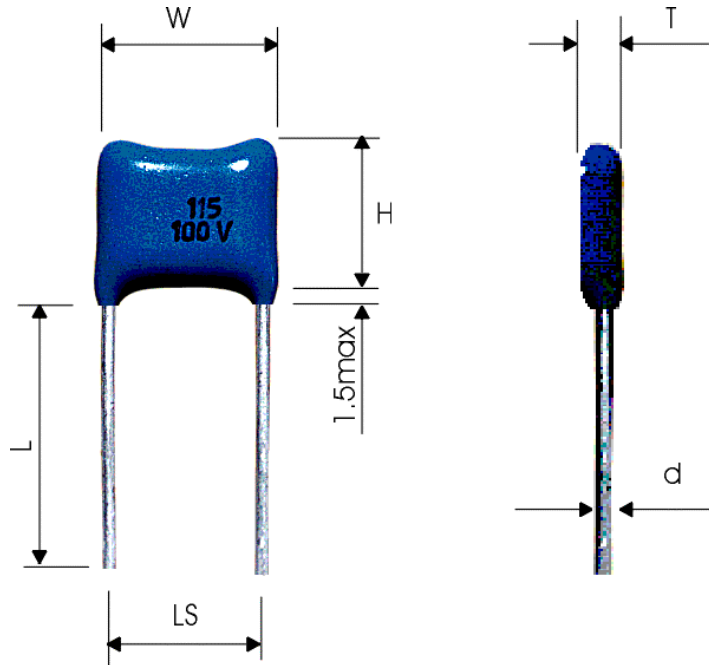

(Unit: mm)

Size	382			502			762			102		144		186		246	
W / H	3,8			5,0			7,6			10		14		18		24	
L	See page 23 Ordering Code																
LS	5,08			5,08			5,08			5,08		10,16		15,24		15,24	
t	3			4,5			4,5			5,5		5,5		6,5		6,5	
d	0,5			0,6			0,6			0,6		0,8		0,8		0,8	
Dielectric R.Voltage	CG	X7R	Y5V	CG	X7R	Y5V	CG	X7R	Y5V	CG	X7R	CG	X7R	CG	X7R	CG	X7R
	50V	222	104	224	183	394	105	563	125	685	823	225	154	475			
100V	222	823	154	822	334	684	473	105	475	683	185	124	395				
250V	122	153	563	472	104	274	223	684	105	473	474	823	684				
300V	331	682	273	332	473	104	153	334	684	223	224	563	274				
500V	271	472	153	182	333	473	822	154	124	153	104	333	224				
1 kV	181	182		122	123		682	683		822	823	183	154	393	474	104	105
2 kV				561	222		332	273		562	123	123	683	273	823	683	334
3 kV							152	682		222	562	682	333	153	563	393	184
4 kV							821	182		152	332	472	183	103	273	223	104
5 kV							331	102		561	222	222	822	392	153	123	473
6 kV										680		122	472	272	123	682	333
7 kV												821	332	182	822	562	223
8 kV														562	562	472	153
9 kV														102	472	332	123
10 kV														561	332	272	103

Note: Rated Voltage is marked only on dimensions 762 and upper-size

Packaging

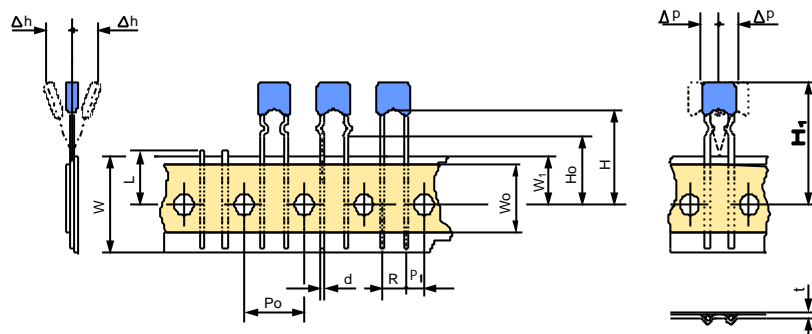

Unit: mm

Symbol	Dimensions	Tolerance
W	18	+ 1.0 - 0
W ₀	12	min
W ₁	9	+ 0.75 - 0.5
t	0.9	max
P ₀	12.7	± 0.3
P ₁ (F=5)	3.85	± 0.7
P ₁ (F=2.5)	5.1	± 0.7
R	2.54; 5.08	+ 0.6 - 0.1
Δp	0	± 1.3 max.
Δh	0	± 2 max.
d	0.5; 0.6	± 0.05
D ₀	4	± 0.2
H	18	+ 2
H ₁	32.2	max.
L	11	max.

Reel

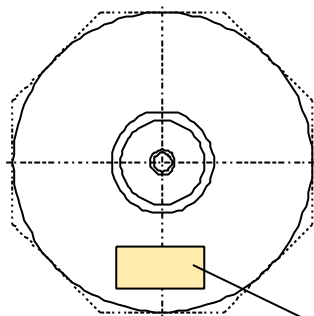
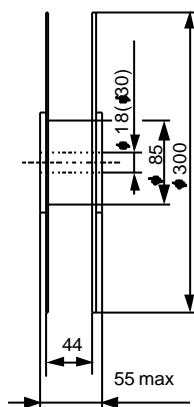

Manufacturer, Ordering Code,
Part Number, Date Packaging,
Quantity

Ammo pack

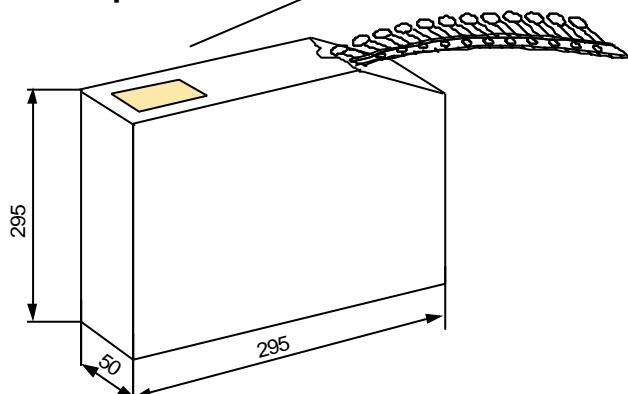

Packaging

(Unit: pcs)

Dimensions	Reel / Ammo pack	Bulk
382	3000	2000
502	2500	2000
762	2000	1500
102	/	1000
144	/	800
186	/	500
246	/	200

Ordering Code

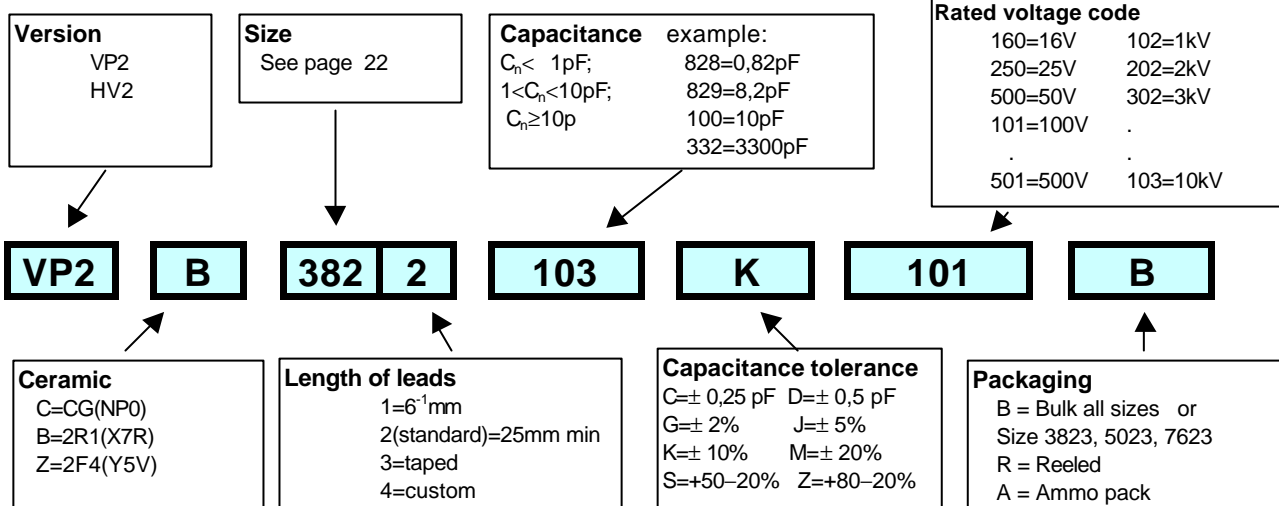

Test methodes

Several periodic and lot-by-lot tests according to the Specification IEC 384-8, 9 and 10 are performed in the Kekon control lab in order to audit the current quality in the MLC production. Some of these tests are performed for both; chip and leaded versions, some of them for chips or leaded capacitors only. Safety capacitors (HM1) are tested according to the special tests (UL 1414 and IEC 384-14).

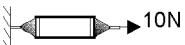
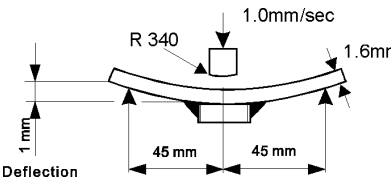
No.	Test	Conditions of test	Performance requirements
1.	Initial measurements: Visual examination Dimensions Capacitance Dissipation factor (tanδ) Insulation resistance Voltage proof Special preconditioning for 2R1 and 2F4 only before a test or sequence of tests (de-ageing process)	10X magnification see dimension tables 1 MHz for C≤1000pF 1 KHz for C>1000pF at 1Vrms for CG and 0,3Vrms for 2R1 and 2F4 as for capacitance 16-500V Rated voltage - Ur >500V 500V 16 - 100V 2,5xUr 200 - 500V 1,5xUr + 100V > 500V 1,2xUr t: 1-5sec, max 50mA For Ur> 1000V in insulating liquid 125°C for 1 hour followed by recovery during 24 hours at standard atmospheric conditions	metalization: no visible detachment, no exposed electrodes ceramics: free of cracks, free of delaminations, no exposed electrodes (for leaded a coating is examined) within specified tolerance within specified tolerance CG: $15 \cdot 10^{-4}$ for C≥50pF $1.5(150/C+7)10^{-4}$ for C<50pF 2R1, 2F4: $350 \cdot 10^{-4}$ 10GΩ or RixC≥100ΩF whichever is less No failure, no breakdown or flashover Bring the capacitance to a defined state - initial value
2.	Robustness of termination: Adhesion test Bending test (chips only) Solderability	 10sec in axial direction for chips and in radial for leaded  1mm of bending for 10sec Flux: 25% colophony in isopropanol Solder: 60/40 Sn/Pb Bath temperature: 235±5°C Immersion time: 2±0.5sec Preheating : 5minutes at 100°C 1-2minutes at 170°C (For leaded no preheating)	No removal of the termination or other signs of damage No signs of damage capacitance decrease : ≤ 10% Electrode (or leads) covered with a smooth and bright solder coating with no more than a small amount of scattered imperfections. They shall not be concentrated in one area.

3.	Resistance to soldering heat	Flux and preheating: as at solderability Bath temperature: 260±5°C Immersion time: 5±0.5sec Recovery: 24 hours at room temperature (For leaded no preheating, immersion of leads to 3mm from body)	No visual defects, Capacitance change $\Delta C/C$: CG - 0.5% or 0.5pF 2R1 -5%/+10% 2F4 -10%/+20% $\tan\delta$, Insulating resistance, Voltage proof: No failure
4.	Leaching resistance (chips only)	Dipping into solder Sn60Pb40 at 260°C for 10sec.	Smooth and bright solder coating on min. 95% of the termination surface.
5.	Temperature coefficient CG(NPO) only or Temperature characteristics of capacitance (2R1, 2F4) Temperature - Voltage characteristics	C measurement in the temperature chamber at 20°C and at maximum and minimum category temperature C measurement in the temperature chamber with applied rated voltage at 20°C and at maximum and minimum category temperature	Capacitance change $\Delta C/C$: CG - 0 ±30 ppm 2R1 - ±15% 2F4 - +30/-80 % $\Delta C/C$ at U_r : CG - 0 ±30 ppm 2R1 - +15/-40 % 2F4 - +30/-90 %
6.	Temperature cycle	Cycle: max. category temp.:30minutes, min. category temp.: 30minutes Number of cycles: 5 Recovery: 24hours Final test limits at 23°C	No mechanical damages Capacitance change $\Delta C/C$: CG: 0.5% or 0.5pF whichever is higher 2R1: ±10% 2F4: ±20% Dissipation factor ($\tan\delta$): ≤ 200% of rated values Insulation resistance: CG ≥ 2.5·10 ⁹ Ω or IRxC ≥ 25 ΩF whichever is less 2R1 ≥ 1·10 ⁹ Ω or IRxC ≥ 25 ΩF whichever is less 2F4 ≥ 1·10 ⁹ Ω or IRxC ≥ 25 ΩF whichever is less
7.	Damp heat	56 days (21 days for 2F4), at 40°C, 96% relative humidity, ½ sample no voltage applied ½ 1.5 Vdc applied Recovery: 24 hours Final test limits at 23°C	Capacitance change $\Delta C/C$: CG - less than 2% or 1 pF, whichever is higher 2R1 - ±15% of initial values 2F4 - ±30% of initial values Dissipation factor ($\tan\delta$): ≤200% of rated value Insulation resistance: CG ≥ 2.5·10 ⁹ Ω or IRxC ≥ 25 ΩF whichever is less 2R1 ≥ 1·10 ⁹ Ω or IRxC ≥ 25 ΩF whichever is less 2F4 ≥ 1·10 ⁹ Ω or IRxC ≥ 25 ΩF whichever is less
8.	Life test	1000 hours at 150% of rated voltage at maximal category temperature. Recovery: 24 hours Final Test limits at 23°C	Capacitance change $\Delta C/C$: CG - less than 2% or 1 pF, whichever is higher 2R1 - ±20% of initial values 2F4 - ±30% of initial values Dissipation factor ($\tan\delta$): All 3 types: ≤ 200% of rated values Insulation resistance: CG ≥ 4·10 ⁹ Ω or IRxC ≥ 40 ΩF whichever is less 2R1 ≥ 2·10 ⁹ Ω or IRxC ≥ 50 ΩF whichever is less 2F4 ≥ 2·10 ⁹ Ω or IRxC ≥ 50 ΩF whichever is less



9.	Voltage conditioning	100 hours at 200% of rated voltage at maximal category temperature	No voltage break-downs Insulation resistance: CG $\geq 2.5 \cdot 10^8 \Omega$ or IRxC $\geq 2.5 \Omega F$ whichever is less 2R1 $\geq 1 \cdot 10^8 \Omega$ or IRxC $\geq 2.5 \Omega F$ whichever is less 2F4 $\geq 1 \cdot 10^8 \Omega$ or IRxC $\geq 2.5 \Omega F$ whichever is less
10.	Aging rate (constant)	Heating of capacitor at upper category temp. for 2hours. Recovery 1 hour. Aging at constant temperature 23°. C- measuring (at 23°C) every hour decade up to 1000 hours.	$\Delta C/C$ in % per decade hour: 2R1 $\leq 2\%$ Y5V $\leq 6\%$ Ct = C1 (1-k/100.lgt) k = 100(Ct ₁ - Ct ₂)/(Ct ₁ .lgt ₂ - Ct ₂ .lgt ₁) Ct - capacitance t hours after the start of the ageing process C1 - capacitance 1 hour after the start of the ageing process k - the ageing constant t - the time in hour from the start of the ageing process

Additional tests on request.

Production tests

The following production tests:

- 100% capacitance and tanδ testing
- 100% voltage proof testing
- 100% visual control

and with the maintenance of our Quality Assurance Program we ensure the conformance of our products to customers requirements.

Basic capacitor formulas

1. Capacitance (Farads)

$$C = N \frac{\epsilon A}{113.1 d}$$

N - layers

A - area in mm²

d - dielectric thickness in mm

ε - dielectric constant

(CG : 90, 2R1: 3000, 2F4: 15000)

2. Total impedance of a capacitor (Ohms)

$$Z = \sqrt{R^2 + (X_C - X_L)^2}$$

$$X_C = \frac{1}{\omega C} \quad \text{Capacitive reactance (Ohms)}$$

$$X_L = \omega L \quad \text{Inductive reactance (Ohms)}$$

R - series resistance

3. Dissipation factor ($10^4 = 10^{-2}\%$)

$$DF = \tan \delta = \frac{R}{X_C} = R \omega C$$

4. Temperature characteristic

$$\text{NP0 (ppm/°C): } TC = 10^6 \frac{C_T - C_{25}}{(T - 25)C_{25}}$$

$$\text{2R1, 2F4 (%): } TC = 100 \frac{C_T - C_{25}}{T - 25}$$

5. Reliability

$$\frac{t_1}{t_2} = \left(\frac{U_2}{U_1} \right)^n \exp \left(\frac{E_a}{k} \left(\frac{1}{T_1} - \frac{1}{T_2} \right) \right)$$

t - median time to failure (MTTF)

U - applied voltage

T - test temperature

n - voltage stress exponent (4.3 ± 0.9)

E_a - activation energy (1.06 ± 0.07 eV)

k - Boltzmann constant (8.6 · 10⁵ eV/K)

KEKON in Europe



KEKON in Slovenia

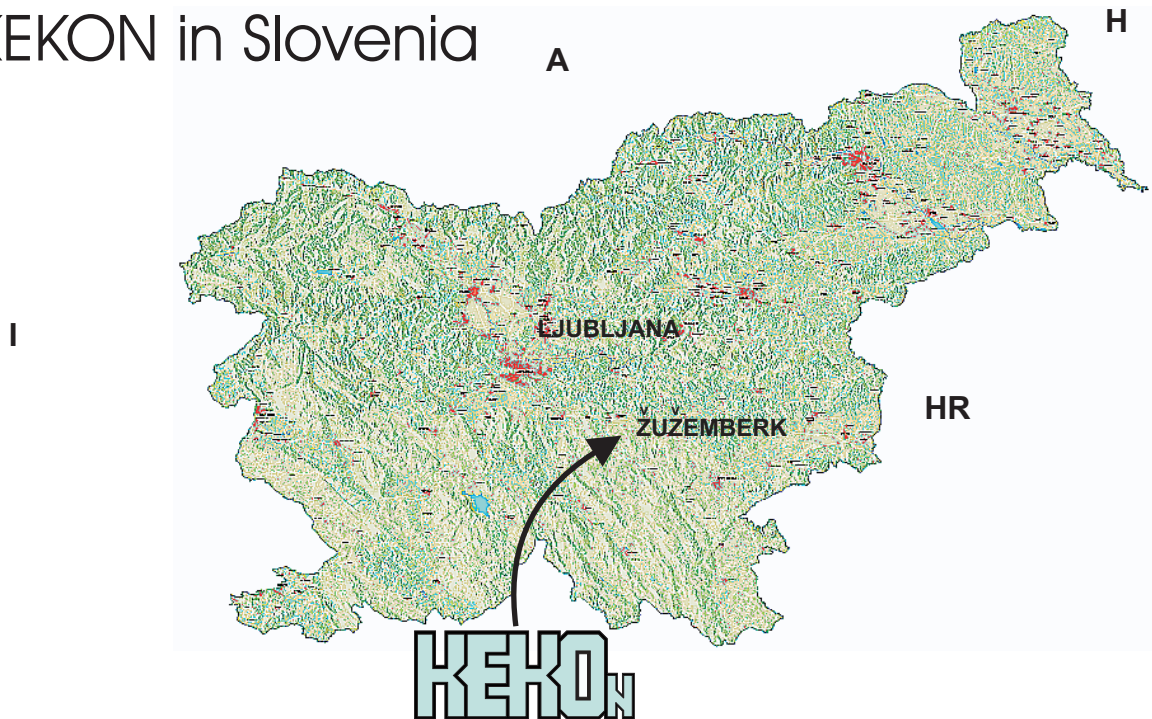

Kekon Ceramic Capacitors

Grajski trg 15

SI-8360 Žužemberk

Slovenia

Phone: +386 730 87703

+386 730 88033

Fax: +386 730 87471

E-mail: info@kekon.com

www.kekon.com
